

ERLO

Drills / Units / CNC

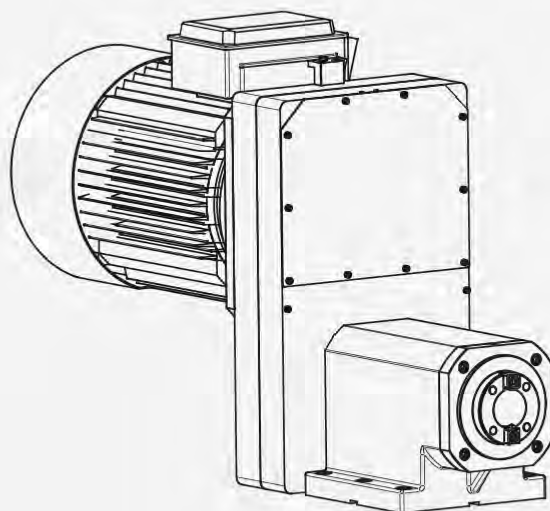

designed by **IBERMACH**
Special Machinery s.r.l. - ERLO Group

MACHINING UNIT HEAD

FEEDING SLIDES

CUSTOMIZED

ASSEMBLIES

ERLO

Drills / Units / CNC

Since its establishment in 1962, **ERLO** has distinguished in manufacturing high quality machinery and demonstrated reliability, as proved by the thousands of drilling and tapping machines sold since then, being the users our best sellers.

In 2003 **ERLO** manufactured its first machining unit for the construction of an automatic machine and since then, it has been designing and manufacturing different models, always according to the **customer's** needs.

The year 2012 **ERLO** decided to make available this range of machining units, together with the feeding slides, multispindle heads and all necessary equipment, for its **customer's** installations.

This new catalogue that you are holding, aims to expand this offer and make available all the necessary elements to allow you to easily integrate **our heads in the solution you have devised. We are at your disposal** to design and make any adjustments you would need, please consult.



CS. 14



Page 4

CR. 14



CG.16



Page 6



CA-16 Slide

CAN-16 Slide



SB Column



VH Multispindle head



Tool holder

CGCM.30



Page 8



CA-30 Slide

CAN-30 Slide



SB Column



VH Multispindle head



Tool holder

CG.30



Page 10



CA-30 Slide

CAN-30 Slide



SB Column



Tool holder

CG.40



Page 12

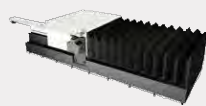

CA-40 Slide



VH Multispindle head



Angular headstock
*request for models



Tool holder



Customized desing
under request

CG.50



Page 14



VH Multispindle head



Angular headstock
*request for models



Customized desing
under request



Tool holder

Cabecal revolver



Page 16



Angular headstock
*request for models



Customized desing
under request



Tool holder



Drilling unit with pneumatic feed quill



CS 14

Maximum drilling capacity in steel (700 N/mm ²)	Ø 14 mm
Revolutions range (50 Hz)	304-7250 r.p.m.
Maximum turning torque	35 Nm.
Spindle Cone	B-16, TR16, ER-20
Weight (without motor)	~55 Kg.
Available motors (50 Hz)	1.000 r.p.m. / 1.1 Kw. 1.500 r.p.m. / 1.5 Kw. 3.000 r.p.m. / 2.2 Kw.

[THERE ARE OTHER POSSIBLE COMBINATIONS, PLEASE CONSULT]



DIMENSIONS

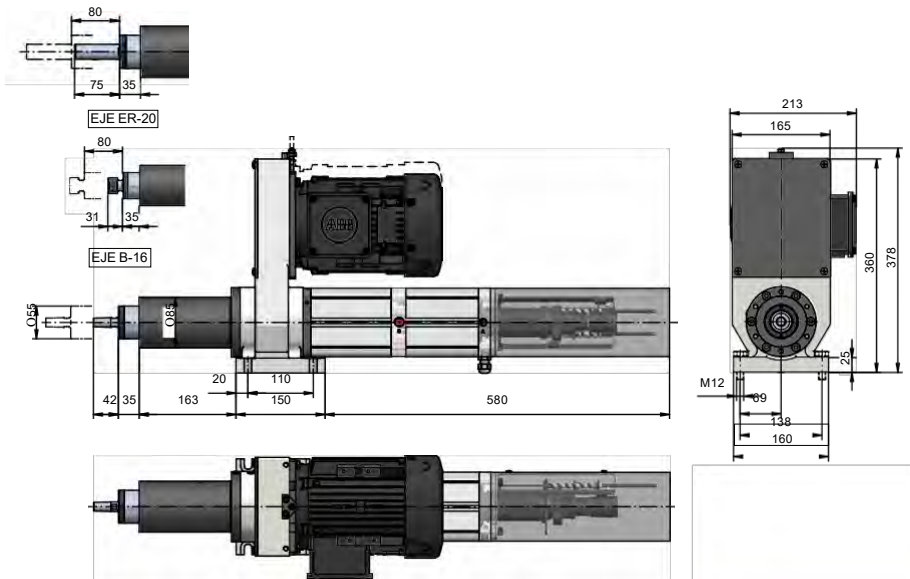

COMBINABLE ELEMENTS



VH Multispindle head



Tool holder



Tapping unit with pneumatic feed quill



CR 14

Maximum drilling capacity in steel (700 N/mm ²)	M12
Revolutions range (50 Hz)	304-7250 r.p.m.
Maximum turning torque	35 Nm.
Spindle Cone	B-16, TR16, ER-20
Weight (without motor)	~55 Kg.
Available motors (50 Hz)	1.000 r.p.m. / 1.1 Kw. 1.500 r.p.m. / 1.5 Kw. 3.000 r.p.m. / 2.2 Kw.

[THERE ARE OTHER POSSIBLE COMBINATIONS, PLEASE CONSULT]



DIMENSIONS

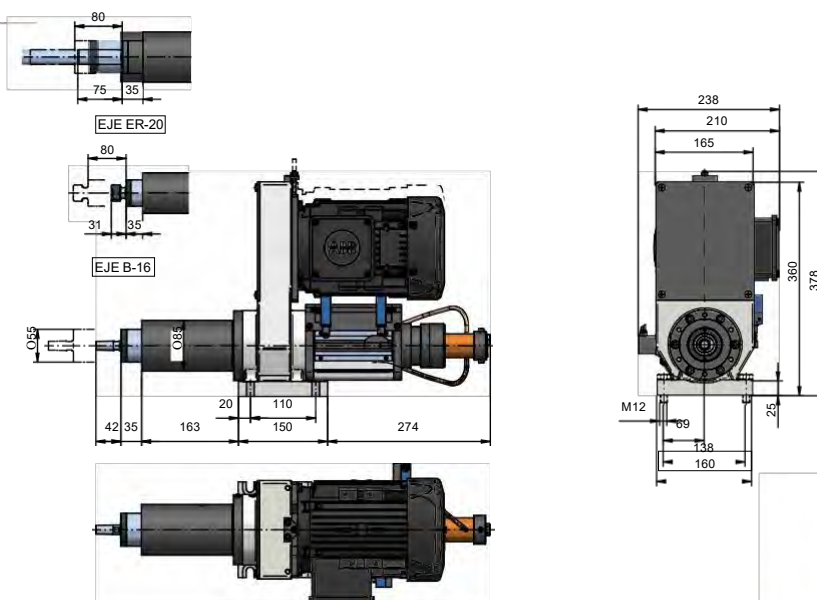

COMBINABLE ELEMENTS



VH Multispindle head



Tool holder

* Measures can vary without previous notice. Ask for the updated drawing in every case.

Machining unit for modular assembly



CG.16

Maximum drilling capacity in steel (700 N/mm ²)	Ø 16 mm
Maximum tapping capacity in steel (700 N/mm ²)	M12
Revolutions range (50 Hz)	210—9000 r.p.m.
Maximum turning torque	31 Nm.
Spindle Cone	ISO 30 DIN 2080
Weight (without motor)	~40 Kg.
Available motors (50 Hz)	750 r.p.m. / 0,55 Kw. 1500 r.p.m. / 1,5 Kw 3000 r.p.m. / 2,2 Kw.

[THERE ARE OTHER POSSIBLE COMBINATIONS, PLEASE CONSULT]

OPTIONAL EQUIPMENT



RG: Encoder for rigid tapping and tool positioning.



RU: Rotary joint for tool internal cooling.



RGU: Rotary joint + encoder.



Protection bellows for slides guides.

** Pneumatic clamping (AN) and hydraulic clamping (AH), **NOT AVAILABLE.**

COMBINABLE ELEMENTS



CA-16 Slide



CAN-16 Slide



SB Column



VH Multispindle head



Tool holder

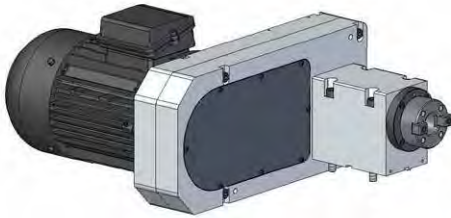
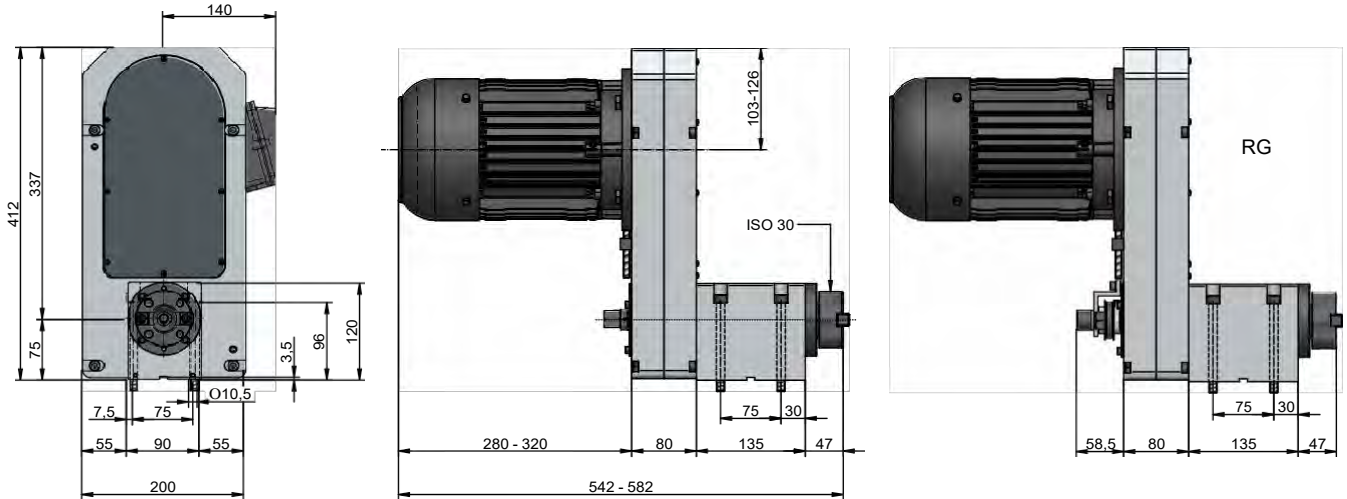

RECOMMENDED ACCESSORY

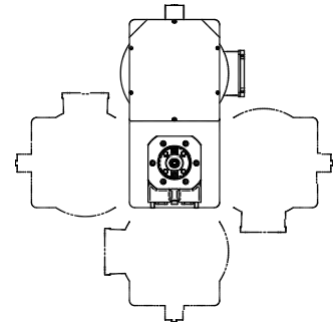

The pulley box as well as the connectors box of the motor can be assembled in any of these positions.

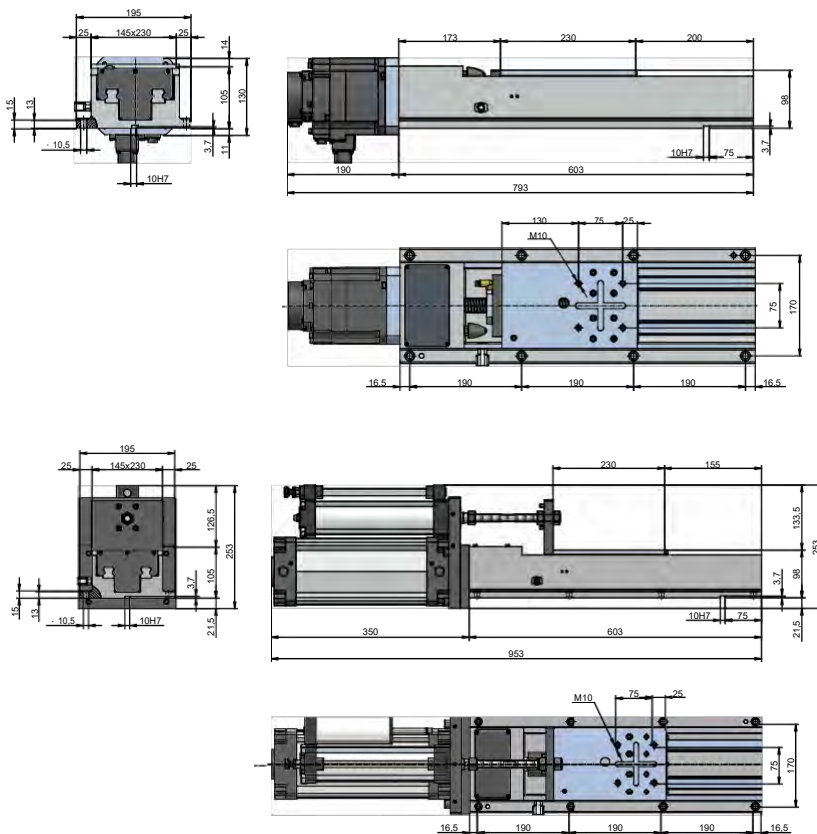

CA.16

Stroke	200 mm
Ball spindle	Ø25x5
Thrust force (kN)	5,4
Weight with motor	40 Kg.
Weight without servomotor	50 Kg.

CAN.16

Stroke	100 mm
Max. Thrust to 6 bar (kN)	4,4
Weight	65 Kg.

* Measures can vary without previous notice. Ask for the updated drawing in every case.

CGCM.30



Machining unit
for modular
assembly.
**Special design
for Multispindle
head.**



ø 30 mm M 18 NO

CGCM.30

Maximum drilling capacity in steel (700 N/mm ²)	Ø 30 mm
Maximum tapping capacity in steel (700 N/mm ²)	M18
Revolutions range (50 Hz)	308—8961 r.p.m.
Maximum turning torque	59 Nm.
Spindle Cone	ISO40 DIN 2080
Weight (without motor)	~ 75 Kg.
Available motors (50 Hz)	750 r.p.m. / 1,5 Kw. 1000 r.p.m. / 2,2 Kw. 1500 r.p.m. / 4 Kw. 3000 r.p.m. / 4 Kw.

[THERE ARE OTHER POSSIBLE COMBINATIONS, PLEASE CONSULT]

OPTIONAL EQUIPMENT



RG: Encoder for rigid tapping and tool positioning.



RU: Rotary joint for tool internal cooling.



RGU: Rotary joint + encoder.



Protection bellows for slides guides.

** Pneumatic clamping (AN) and hydraulic clamping (AH), **NOT AVAILABLE.**

COMBINABLE ELEMENTS



CA.30: Feed slide with or without servo coupling joint.

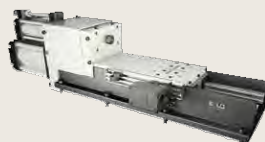

CAN.30: Oleopneumatic feed slide.



SB Column



VH Multispindle head



Tool holder

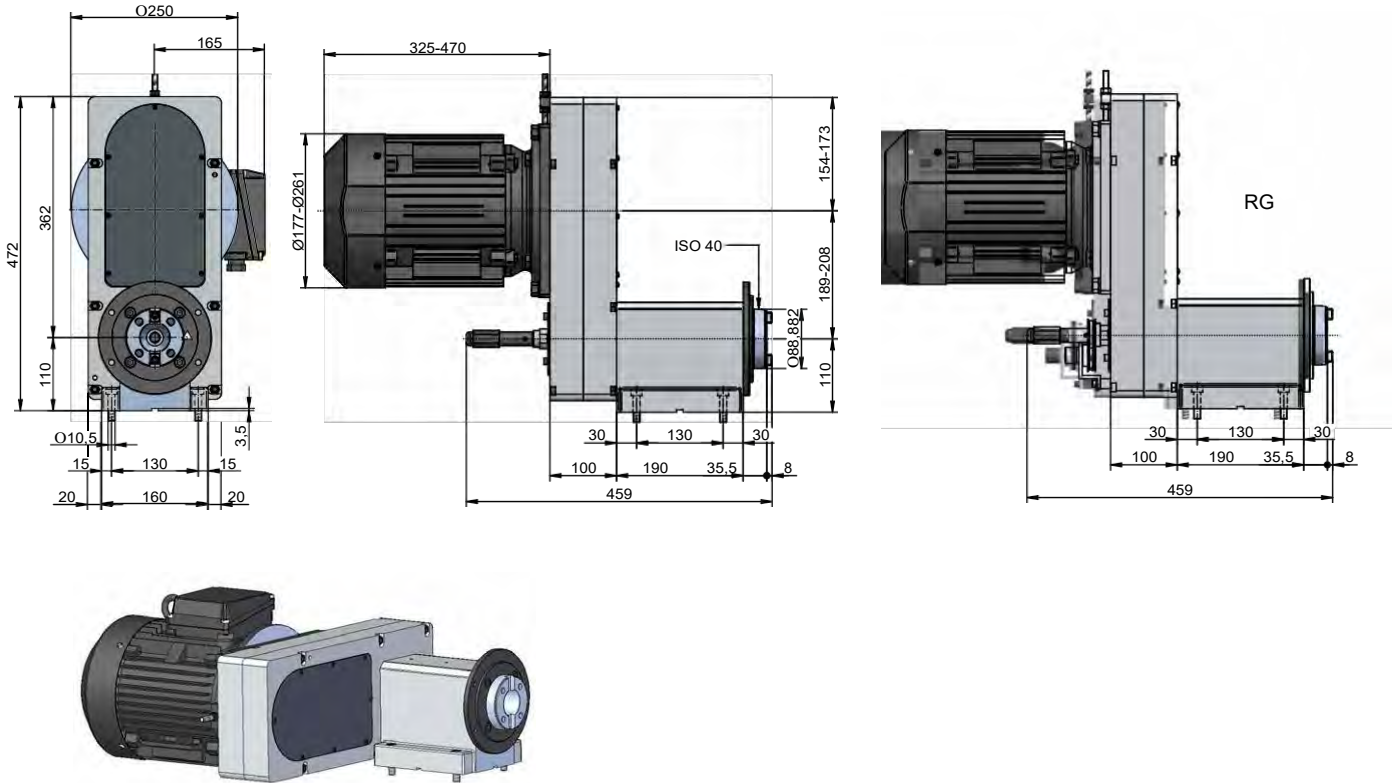

RECOMMENDED ACCESSORY

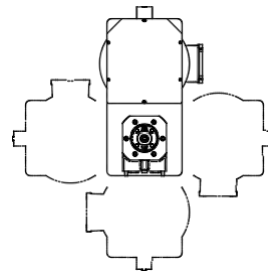
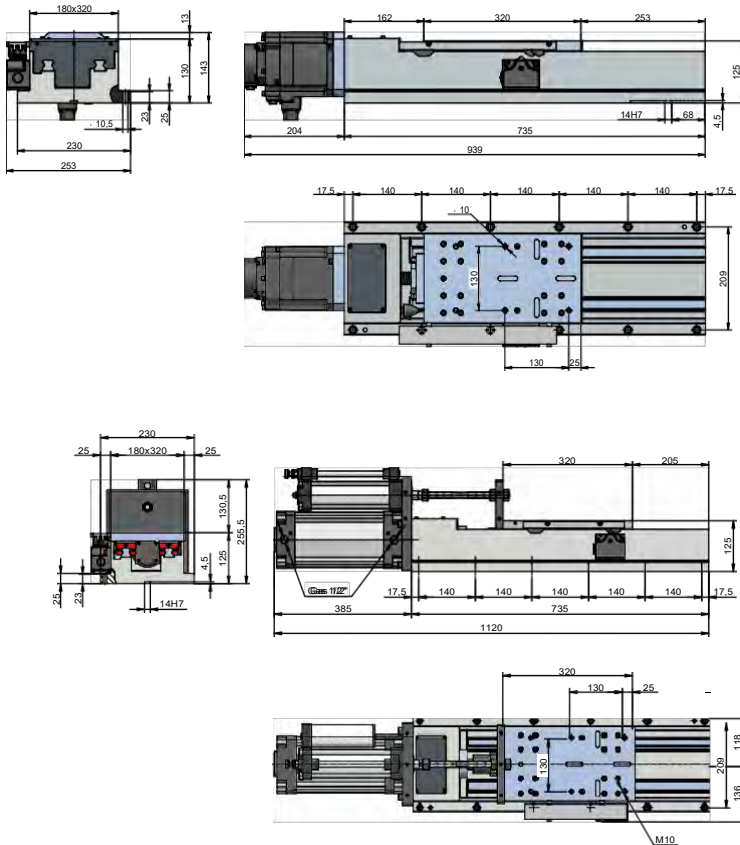

The pulley box as well as the connectors box of the motor can be assembled in any of these positions.

CA.30/250

Stroke	250 mm
Thrust force (kN)	Up to 8
Ball spindle (mm)	Ø25x5
Weight without motor	68 Kg.
Weight with motor	78 Kg.

CA.30/350

Stroke	350 mm
Thrust force (kN)	Up to 8
Ball spindle (mm)	Ø25x5
Weight without motor	80 Kg.
Weight with motor	90 Kg.

CAN.30

Stroke	150 mm
Thrust force to 6 bar (kN)	7
Weight	65 Kg.

* Measures can vary without previous notice. Ask for the updated drawing in every case.



Machining unit for modular assembly



Available in NORMS DIN 2080 / DIN 69871 / MAS 403-BT

CG.30

Maximum drilling capacity in steel (700 N/mm ²)	Ø 30 mm
Maximum tapping capacity in steel (700 N/mm ²)	M18
Revolutions range (50 Hz)	328—3834 r.p.m.
Maximum turning torque	56 Nm.
Spindle Cone	ISO 40
Weight (without motor)	~65 Kg.
Available motors (50 Hz)	750 r.p.m. / 1,5 Kw. 1000 r.p.m. / 2,2 Kw. 1500 r.p.m. / 4 Kw. 3000 r.p.m. / 4 Kw.

[THERE ARE OTHER POSSIBLE COMBINATIONS, PLEASE CONSULT]

OPTIONAL EQUIPMENT



RG: Encoder for rigid tapping and tool positioning.



RU: Rotary joint for tool internal cooling.



RGU: Rotary joint + encoder.



AN: Pneumatic clamping (5,5 bar.)



AH: Hydraulic clamping (20 bar.)

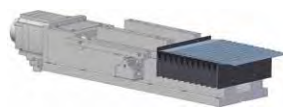

Protection bellows for slides guides.

COMBINABLE ELEMENTS



CA.30: Feed slide with or without servo coupling joint.

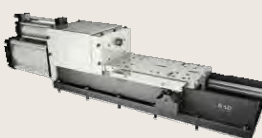

CAN.30: Oleopneumatic feed slide.



SB Column



Tool holder

DIMENSIONS

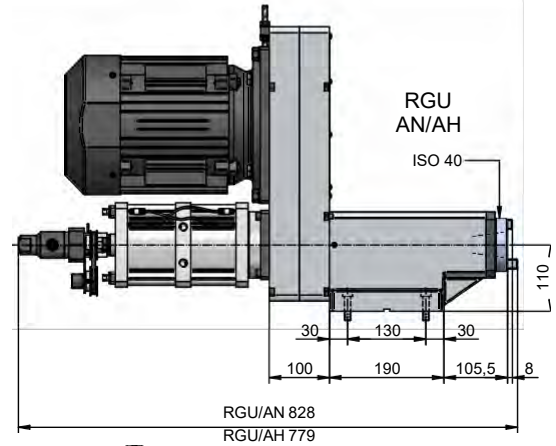
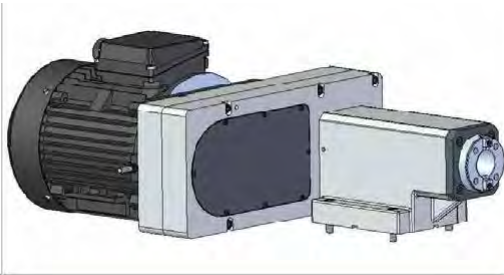
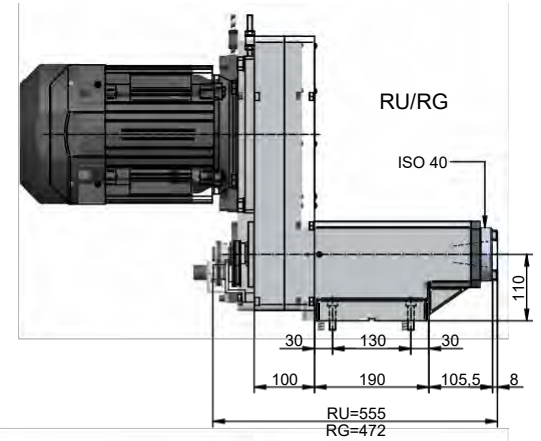
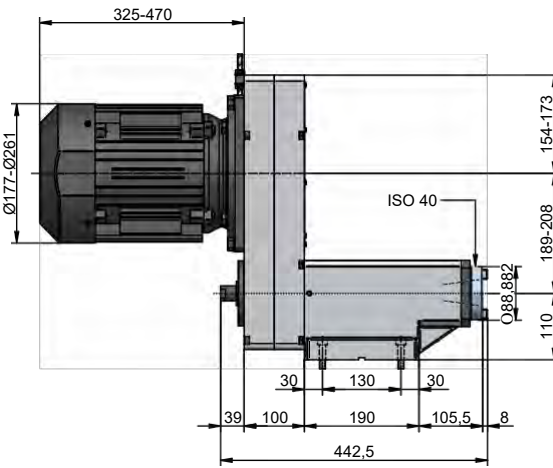
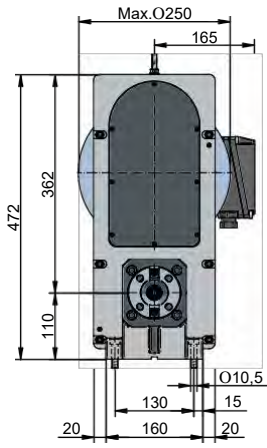

RECOMMENDED ACCESSORY

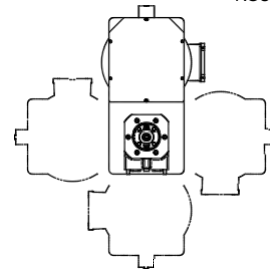
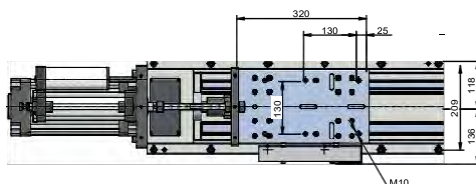
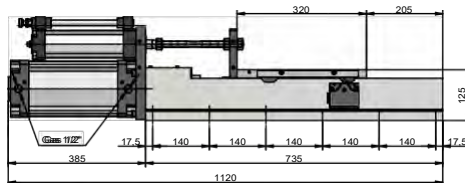
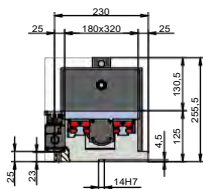
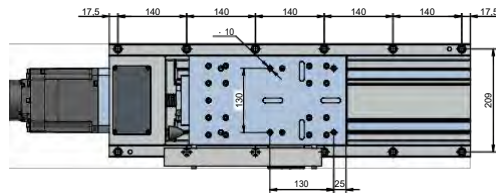
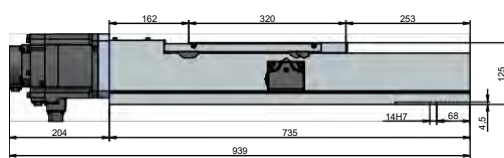
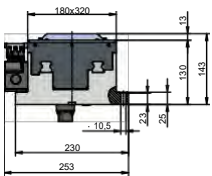

The pulley box as well as the connectors box of the motor can be assembled in any of these positions.

CA.30/250

Stroke	250 mm
Thrust force (kN)	Up to 8
Ball spindle (mm)	Ø25x5
Weight without motor	68 Kg.
Weight with motor	78 Kg.

CA.30/350

Stroke	350 mm
Thrust force (kN)	Up to 8
Ball spindle (mm)	Ø25x5
Weight without motor	80 Kg.
Weight with motor	90 Kg.

CAN.30

Stroke	150 mm
Thrust force to 6 bar (kN)	7
Weight	100 Kg.

* Measures can vary without previous notice. Ask for the updated drawing in every case.

Machining unit for modular assembly



Available in NORMS DIN 2080 /
DIN 69871 / MAS 403-BT



CG.40

Maximum drilling capacity in steel (700 N/mm ²)	Ø 40 mm
Maximum tapping capacity in steel (700 N/mm ²)	M24
Revolutions range (50 Hz)	322—2175 r.p.m.
Maximum turning torque	228 Nm.
Spindle Cone	ISO 40
Weight (without motor)	~ 100 Kg.
Available motors (50 Hz)	1000 r.p.m. / 5,5 Kw. 1500 r.p.m. / 7,5-11 Kw.

[THERE ARE OTHER POSSIBLE COMBINATIONS, PLEASE CONSULT]

OPTIONAL EQUIPMENT



RG: Encoder for rigid tapping and tool positioning.



RU: Rotary joint for tool internal cooling.



RGU: Rotary joint + encoder.



AN: Pneumatic clamping (5,5 bar.)



AH: Hydraulic clamping (20 bar.)

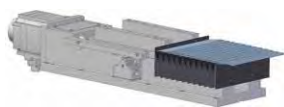

Protection bellows for slides guides.

COMBINABLE ELEMENTS



CA-40 Slide



VH Multispindle head



Angular headstock
*request for models



Tool holder



Customized desing
under request

DIMENSIONS

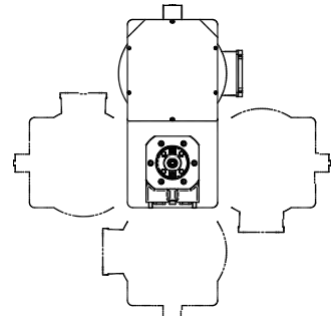
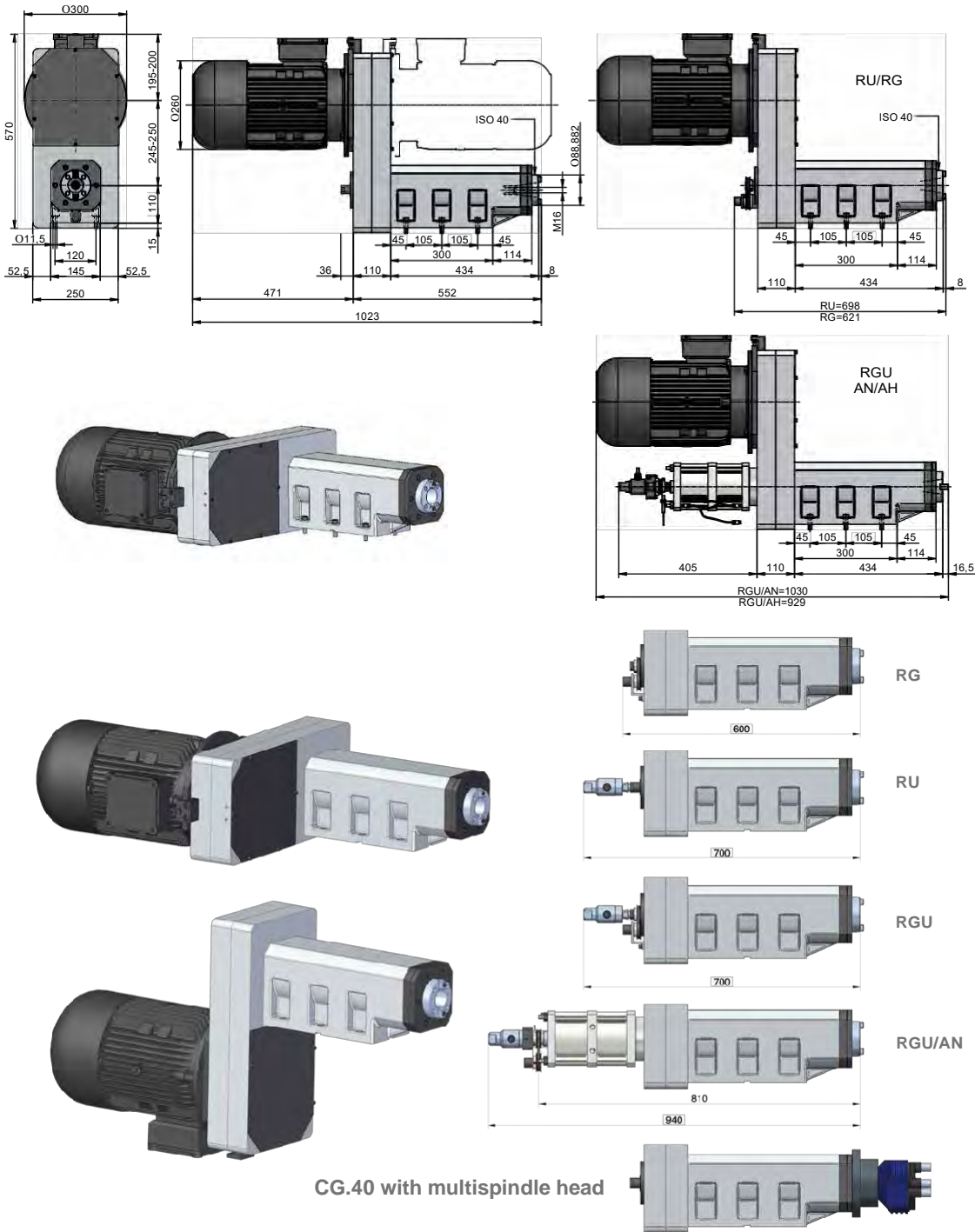

The pulley box as well as the connectors box of the motor can be assembled in any of these positions.

RECOMMENDED ACCESSORY

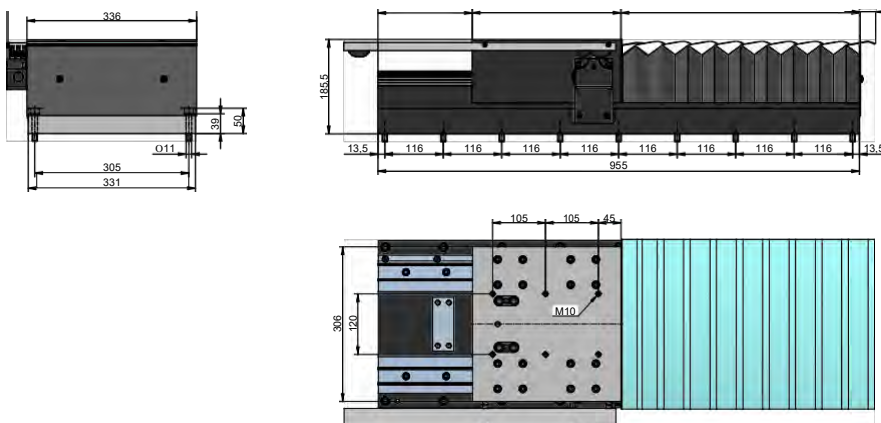

CA.40

Stroke	350/400mm
Thrust force (kN)	Up to 24
Ball spindle(mm)	Ø32x5
Weight without motor	238 Kg.
Weight with motor	250 Kg.

* Measures can vary without previous notice. Ask for the updated drawing in every case.



Machining unit for modular assembly

Available in NORMS DIN 2080 / DIN 69871 / MAS 403-BT



CG.50

Maximum drilling capacity in steel (700 N/mm ²)	Ø 80 mm
Maximum tapping capacity in steel (700 N/mm ²)	M42
Revolutions range (50 Hz)	380—1475 r.p.m.
Maximum turning torque	540 Nm.
Spindle Cone	ISO 50
Weight (without motor)	~300 Kg.
Available motors (50 Hz)	990 r.p.m. / 22 Kw. 1475 r.p.m. / 22 Kw.

[THERE ARE OTHER POSSIBLE COMBINATIONS, PLEASE CONSULT]

OPTIONAL EQUIPMENT



RG: Encoder for rigid tapping and tool positioning.



RU: Rotary joint for tool internal cooling.



RGU: Rotary joint + encoder.



AH: Hydraulic clamping (80 bar.)



** Feed slide with or without servo coupling. **CUSTOMIZED DESIGN UNDER REQUEST.**



** Protection bellows for slides guides. **CUSTOMIZED DESIGN UNDER REQUEST.**

** Pneumatic clamping (AN), **NOT AVAILABLE.**

COMBINABLE ELEMENTS



VH Multispindle head



Angular headstock
*request for models



Customized column design under request



Tool holder

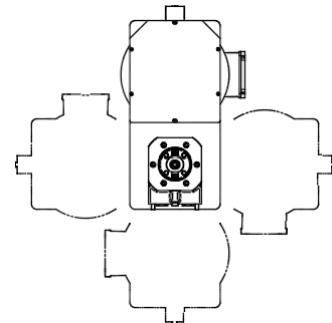
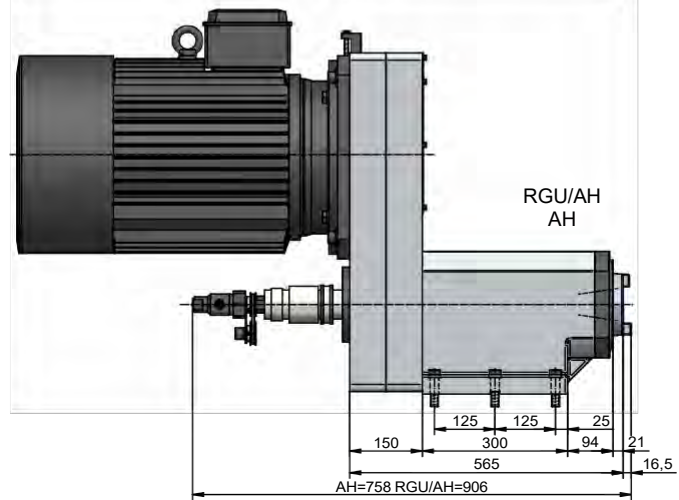
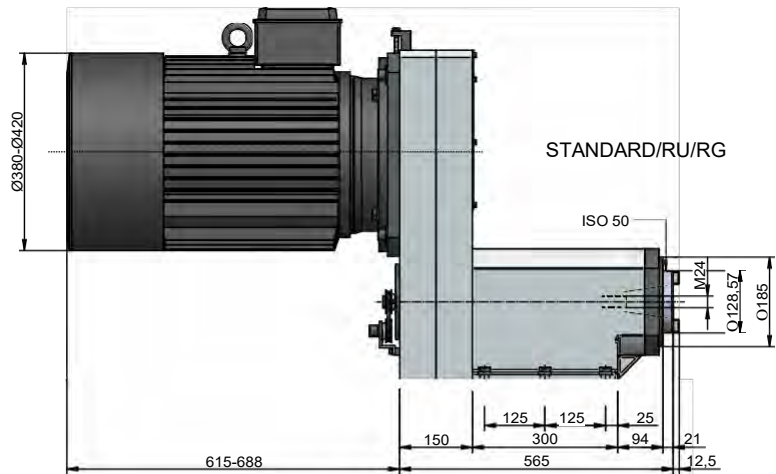
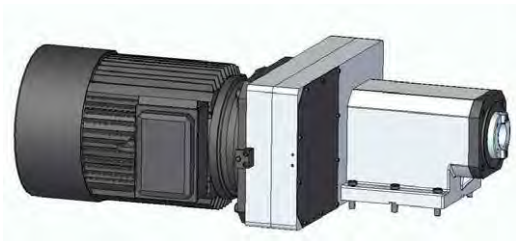
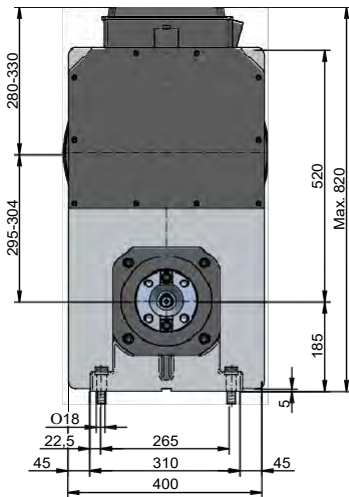

The pulley box as well as the connectors box of the motor can be assembled in any of these positions.

Revolver Heads

Revolver heads to integrate in machining units.



	UR160	UR200	UR250	UR360
Maximum positions number	6	6	6/8	6/8/12
Torque transmissible to spindle (Nm)	80	200	300	800
Rpm. max. spindle	12.000	10.000	10.000	8.000
Spindle positioning accuracy	+/-3"	+/-3"	+/-3"	+/-3"
Motor power (Kw)	4	5	6,5	16
Turning time one position (sec.)	0,9	1,0	1,1	1,5
Crown diam. Hirth	160	200	250	350
A	160	200	250	360
B (depends on the spindle type)	70/80	100/150	100/150	120/170
C	160	200	250	350
D	180	230	290	400
Available spindle type	ABS, HSK , ER, DIN 55058			
Weight (kg) (*only revolver head)	35	60	140	300

- F1: Oil circuit for locking and unlocking of the revolver headstock.
- F2: Cooling entry for tools.
- F3: Fixation holes of the revolver headstock.
- F4: Oil-air entry.
- F5: Electric connector.

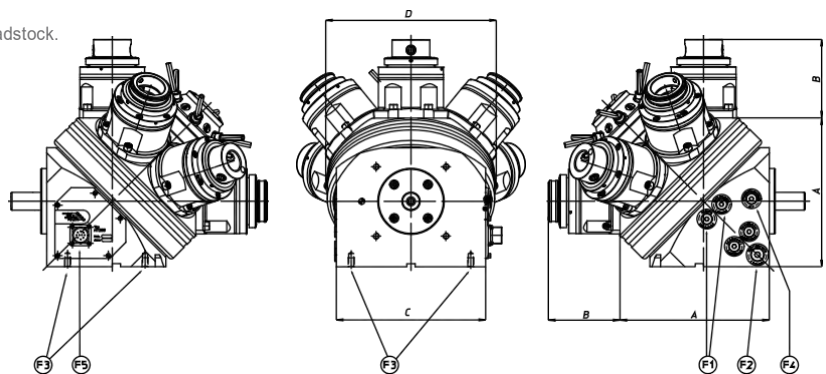

UR160

UR200/6

UR250/6

UR360/6



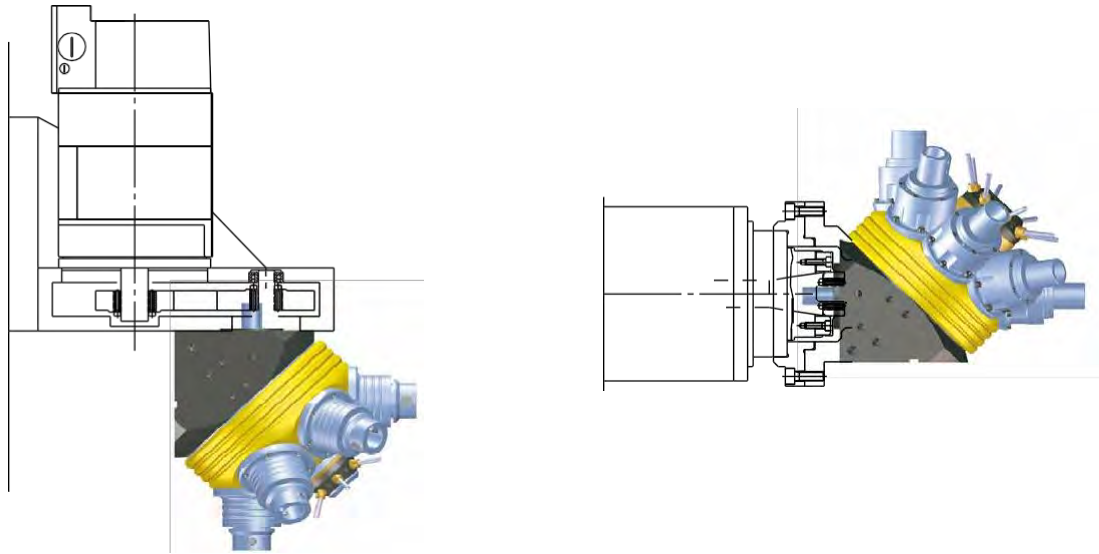
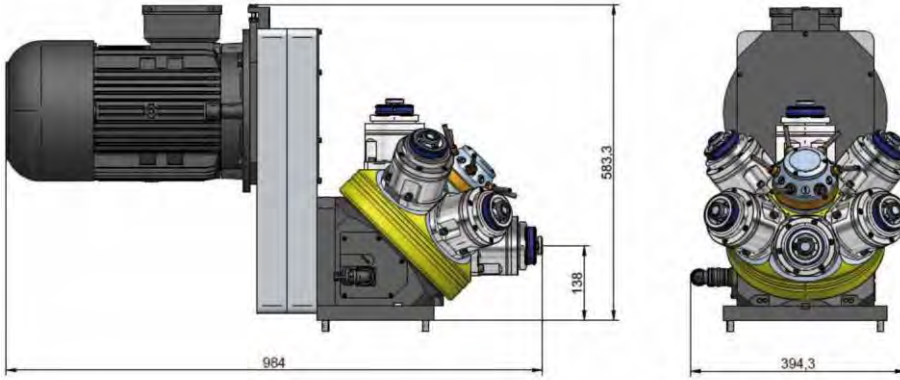

SAMPLES OF DIFFERENT SPECIAL APPLICATIONS



SB Column

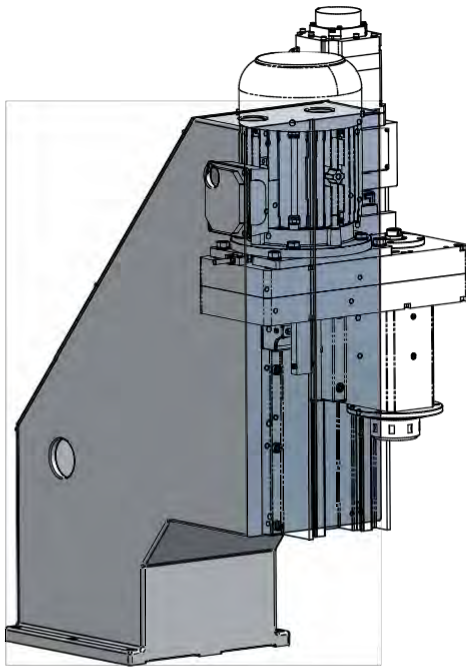

Column for vertical modular assembly of the machining units.

DIMENSIONS

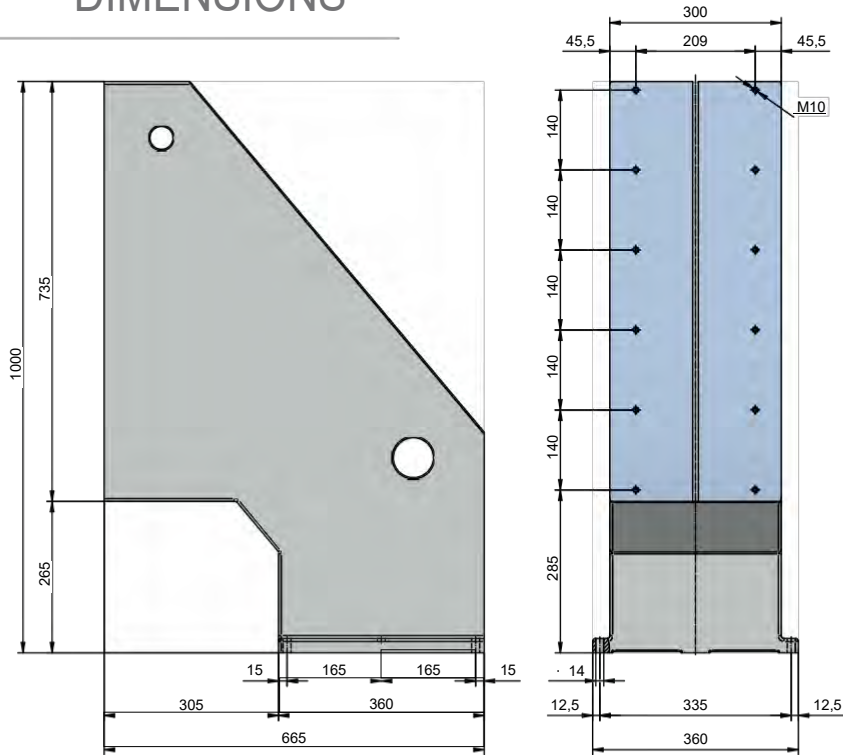

Standard **SB Column** for CG.16, CG.30 and CGCH.30 models.

*The columns and supports for CG.40 and CG.50 models, designed under request.

COMBINABLE ELEMENTS

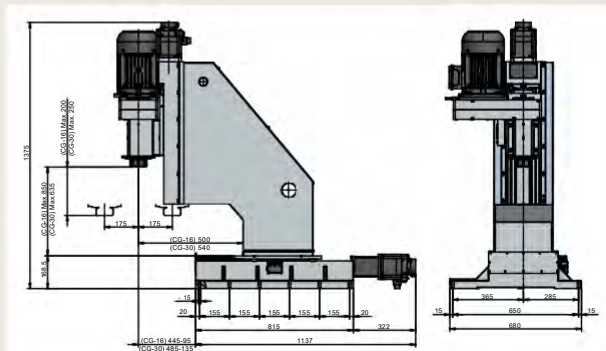

Translation slide in Y axis
Feed slide in Z axis
Machining unit

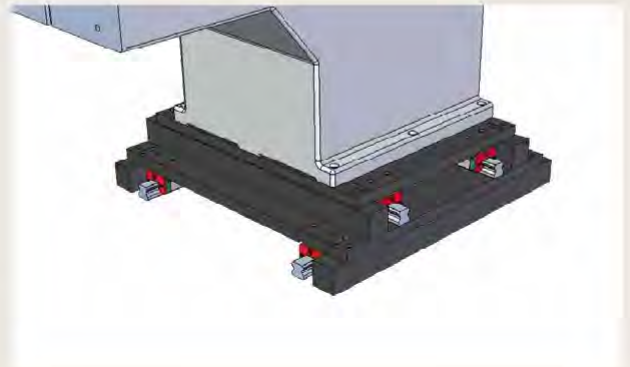

SB Column manual centering guides

Special slides for units assembly in Gantry type bridge structures.

Gantry slide Horizontal left CP.HI

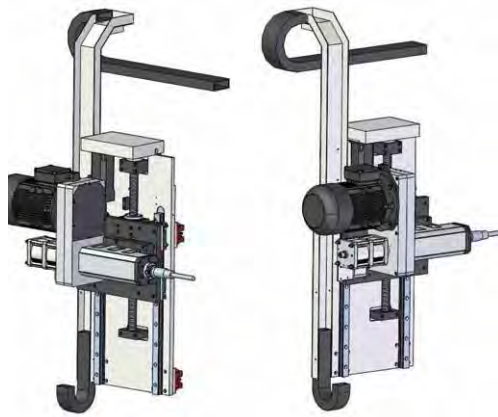

Gantry slide Horizontal right CP.HD

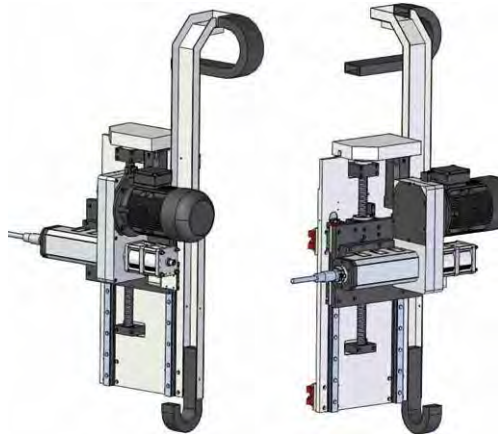

Gantry slide vertical CP.V

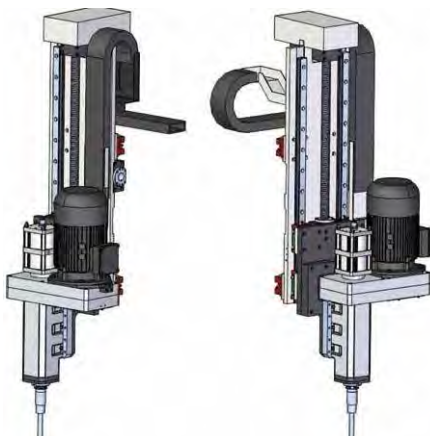

Multispindle headstocks



**Multispindle
headstocks**
to integrate in
machining units.

Multispindle headstock type VH Model	42	43	44	62	63	64	82	83	84
Tapping capacity	2 x M3	3 x M3	4 x M3	2 x M5	3 x M5	4 x M5	2 x M6	3 x M6	4 x M6
Erlo units with which they combine									
CG.16	YES	YES	YES	YES	YES	YES	YES	YES	-
CGCM.30	-	-	-	-	-	-	-	-	YES
CG.40	-	-	-	-	-	-	-	-	-
CG.50	-	-	-	-	-	-	-	-	-

Multispindle headstock type VH Model	102	103	104	132	133	134	182	183	184	252	253	254
Tapping capacity	2 x M8	3 x M8	4 x M8	2 x M12	3 x M12	4 x M12	2 x M14	3 x M14	4 x M14	2 x M20	3 x M20	4 x M20
Erlo units with which they combine												
CG.16	YES	-	-	-	-	-	-	-	-	-	-	-
CGCM.30	YES	YES	YES	YES	YES	-	-	-	-	-	-	-
CG.40	-	-	-	-	-	YES	YES	YES	YES	YES	-	-
CG.50	-	-	-	-	-	-	-	-	-	-	YES	YES



DIMENSIONS

VH042

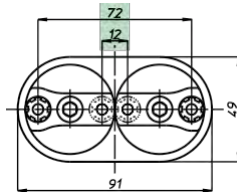

VH043L

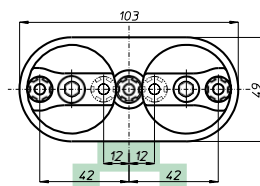

VH043

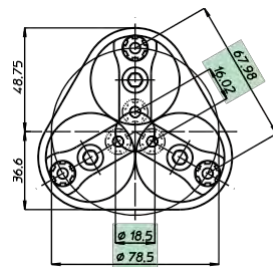

VH044

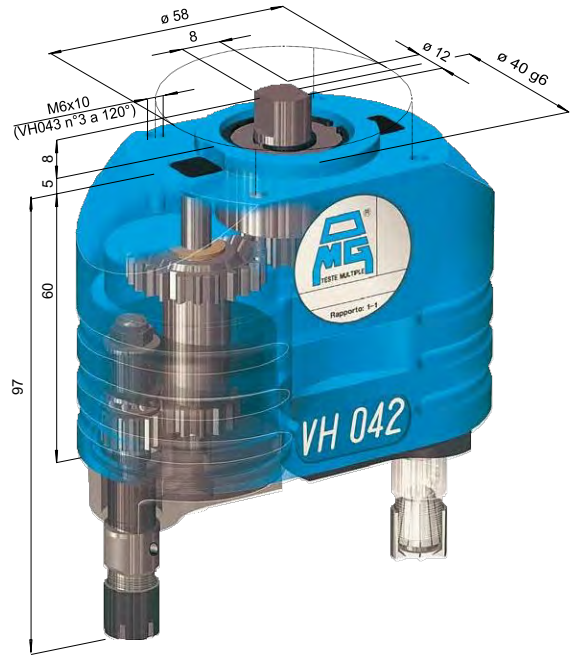
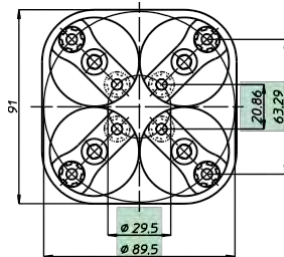

Multispindle headstock model

	VH042	VH043L	VH043	VH044
Article	VH 042 PH	VH 043 LP	VH 043 P	VH 044 P
Spindle type	ER8 máx. Ø5			
Spindle number	2	3	3	4
Min. working area	12 mm	12+12	Ø18,5	Ø29,5
Max. Distance between centers	72	42+42	Ø78,5	Ø89,5
Drilling capacity Steel				Ø4
Drilling capacity Foundry				Ø5
Tapping capacity				M3
Drive relation				1:1
Allowed maximum revolutions				4.000
Weight (Kg)	0,95	1,05	1,4	1,9

* Measures can vary without previous notice. Ask for the updated drawing in every case.

DIMENSIONS

VH062

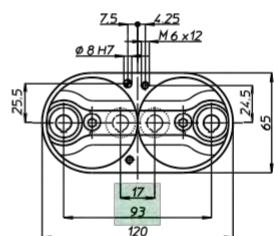

VH063L

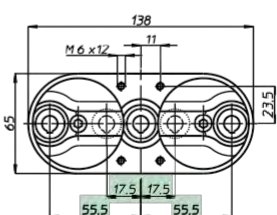

VH063

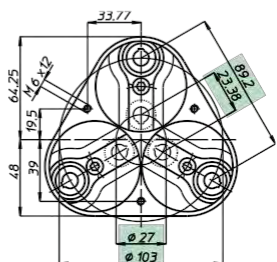

VH064

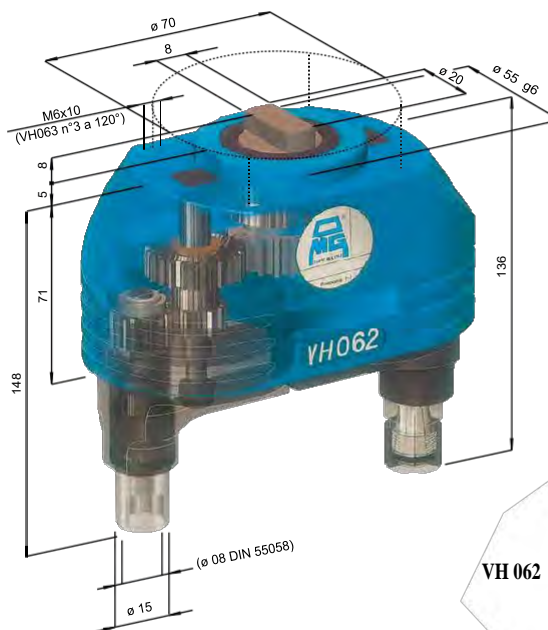
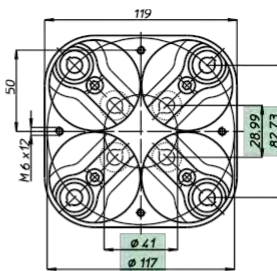

VH 062

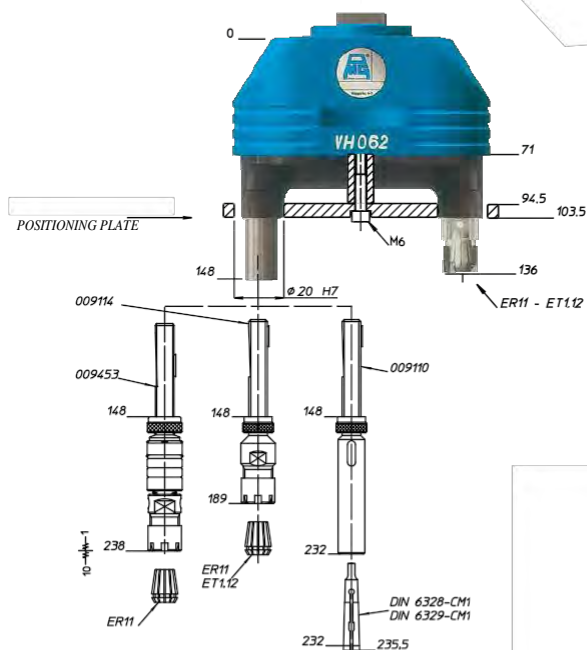

Multispindle headstock model

	VH062	VH063L	VH063	VH064
Article	VH 062 P	VH 063 LP	VH 063 P	VH 064 P
Spindle type	ER11 máx. Ø7			
Article	VH 062 D	VH 063 LD	VH 063 D	VH 064 D
Spindle type	DIN 55058 máx. Ø8			
Spindle number	2	3	3	4
Min. working area	17 mm	17,5+17,5	Ø27	Ø41
Max. Distance between centers	93	55,+55,5	Ø103	Ø117
Drilling capacity Steel	Ø6			
Drilling capacity Foundry	Ø7			
Tapping capacity	M5			
Drive relation	1:1			
Allowed maximum revolutions	4.000			
Weight (Kg)	1,65	1,95	2,3	3,1

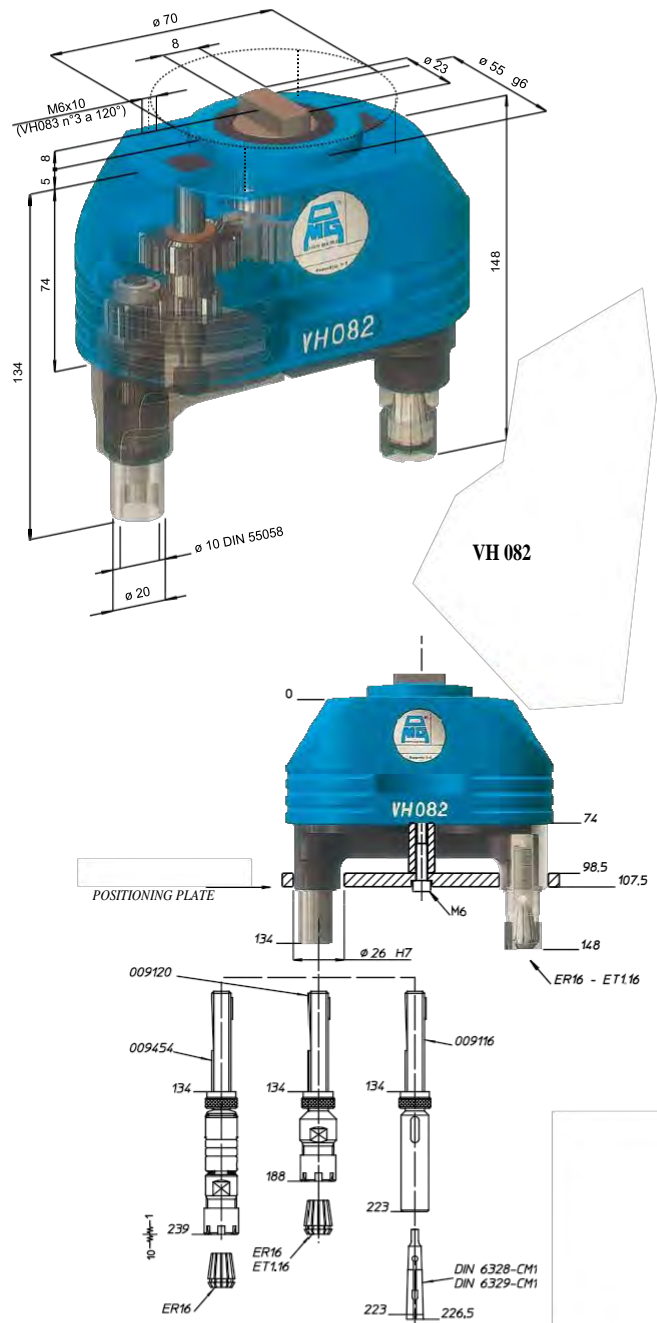
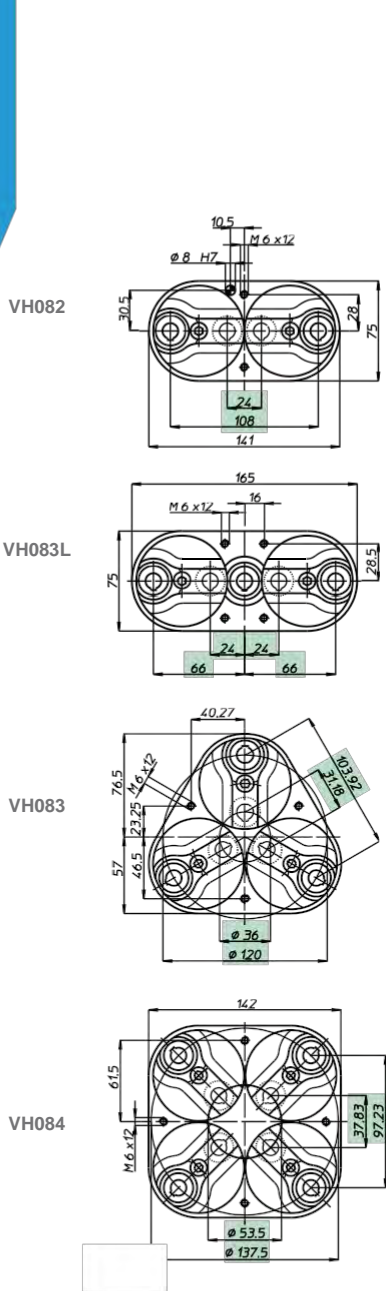

Multispindle headstock model

	VH082	VH083L	VH083	VH084
Article	VH 082 P	VH 083 LP	VH 083 P	VH 084 P
Spindle type	ER16 máx. Ø10			
Article	VH 082 D	VH 083 LD	VH 083 D	VH 084 D
Spindle type	DIN 55058 máx. Ø8			
Spindle number	2	3	3	4
Min. working area	24	24+24	Ø36	Ø53,5
Max. Distance between centers	108	66+66	Ø120	Ø137,5
Drilling capacity Steel	Ø8			
Drilling capacity Foundry	Ø10			
Tapping capacity	M6			
Drive relation	1:1			
Allowed maximum revolutions	4.000			
Weight (Kg)	2,2	2,9	3,4	4,6

DIMENSIONS

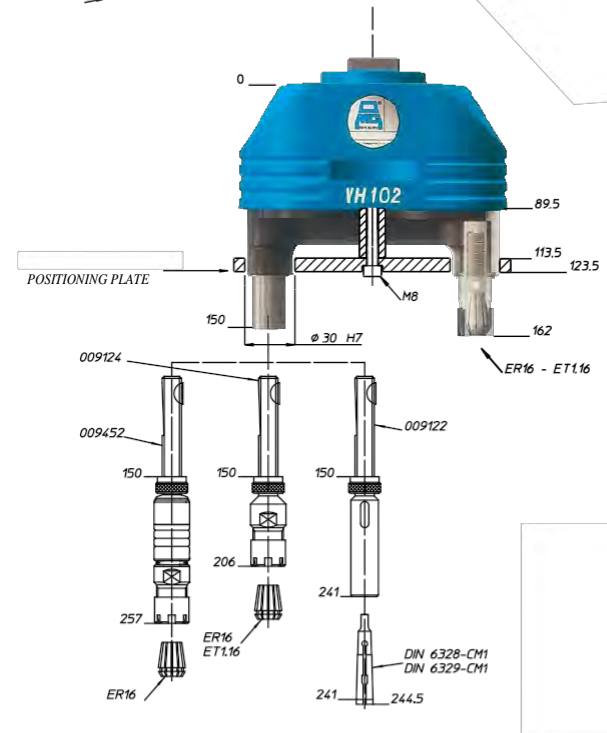
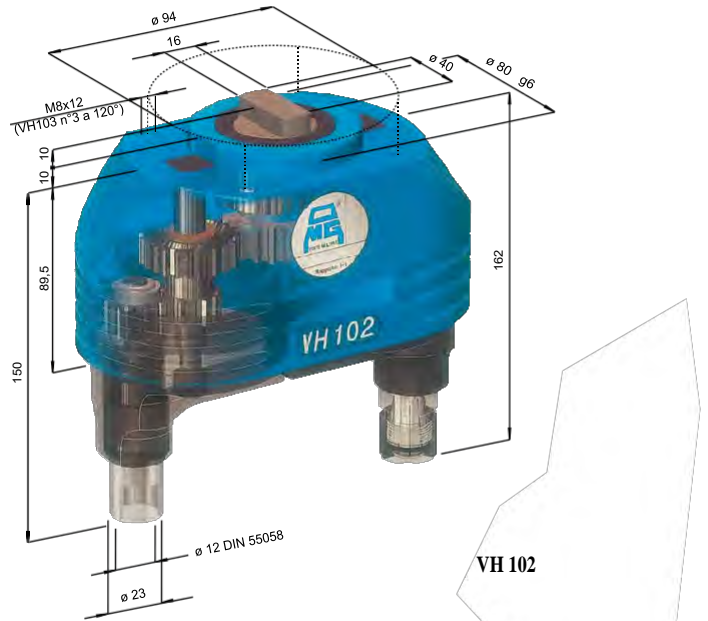
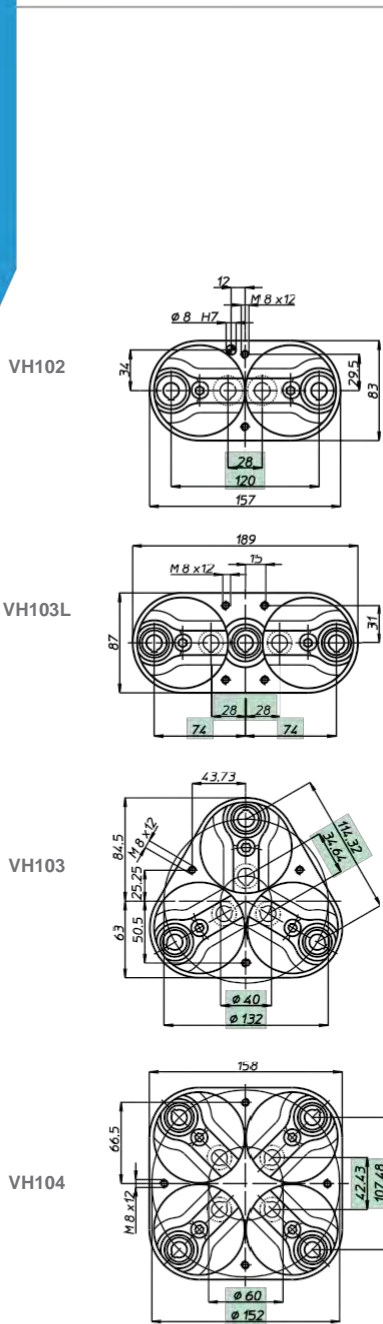

Multispindle headstock model

	VH102	VH103L	VH103	VH104
Article	VH 102 P	VH 103 LP	VH 103 P	VH 104 P
Spindle type	ER16 máx. Ø10			
Article	VH 102 D	VH 103 LD	VH 103 D	VH 104 D
Spindle type	DIN 55058 máx. Ø12			
Spindle number	2	3	3	4
Min. working area	28	28+28	Ø40	Ø60
Max. Distance between centers	120	74+74	Ø132	Ø152
Drilling capacity Steel	Ø10			
Drilling capacity Foundry	Ø12			
Tapping capacity	M8			
Drive relation	1:1			
Allowed maximum revolutions	3.500			
Weight (Kg)	3,5	4,9	4,9	7,2

VH13

DIMENSIONS

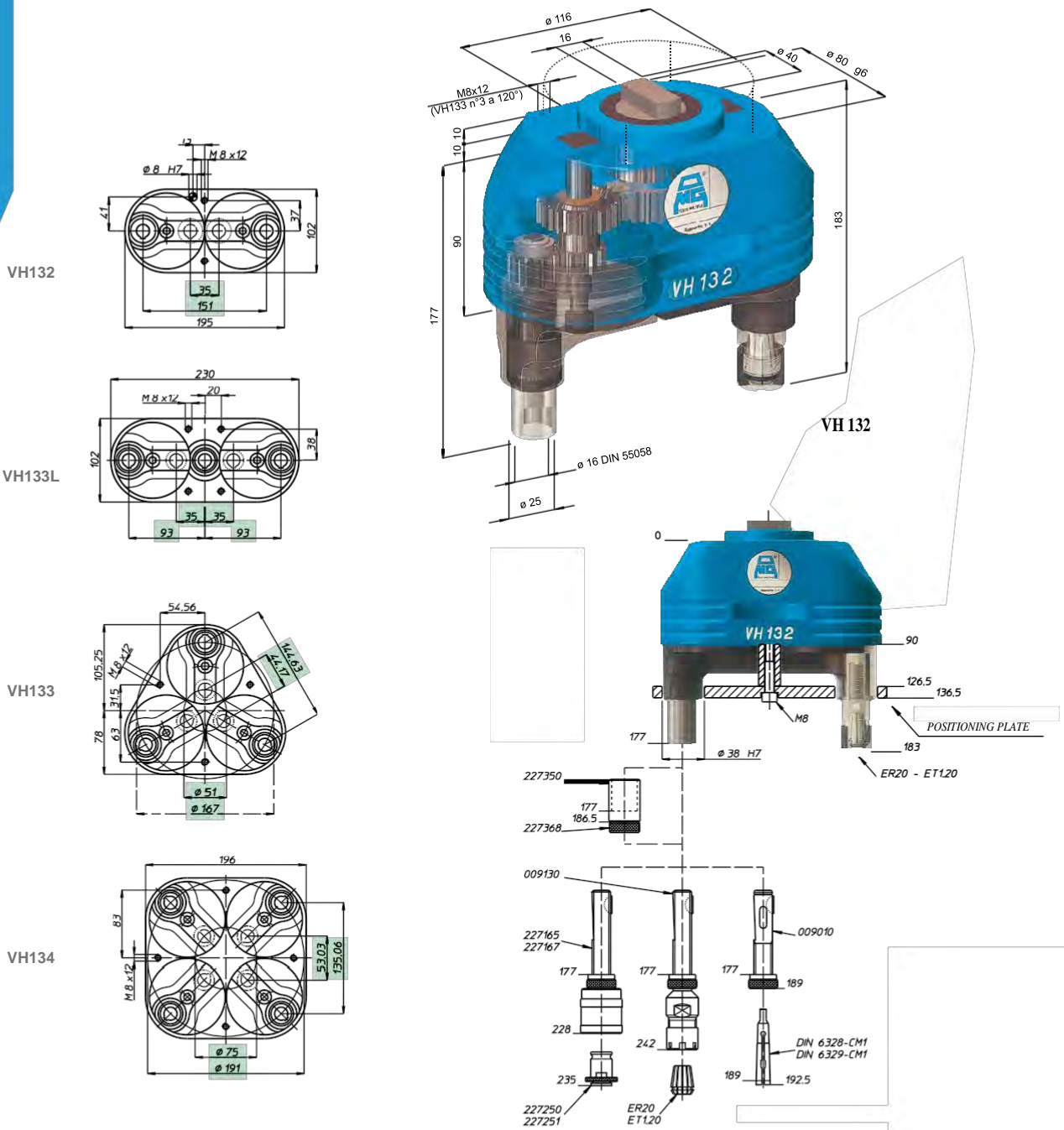

Multispindle headstock model

	VH132	VH133L	VH133	VH134
Article	VH 132 P	VH 133 LP	VH 133 P	VH 134 P
Spindle type	ER20 máx. Ø13			
Article	VH 132 D	VH 133 LD	VH 133 D	VH 134 D
Spindle type	DIN 55058 máx. Ø16			
Spindle number	2	3	3	4
Min. working area	35	35+35	Ø51	Ø75
Max. Distance between centers	151	93+93	Ø167	Ø191
Drilling capacity Steel	Ø13			
Drilling capacity Foundry	Ø14			
Tapping capacity	M12			
Drive relation	1:1			
Allowed maximum revolutions	3.000			
Weight (Kg)	5,3	7,2	7	10,8

DIMENSIONS

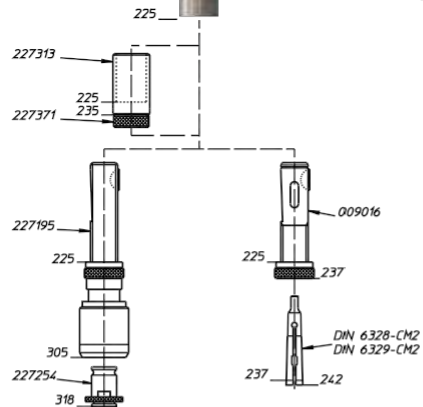
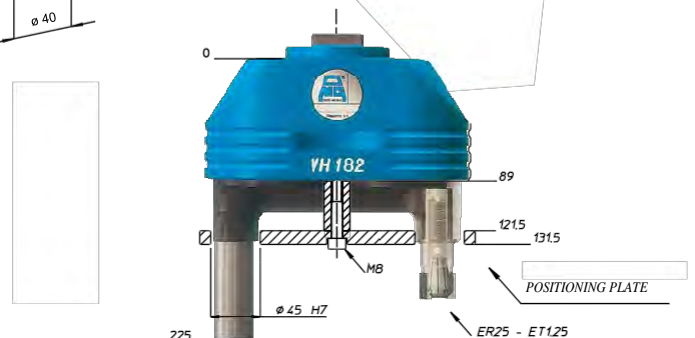
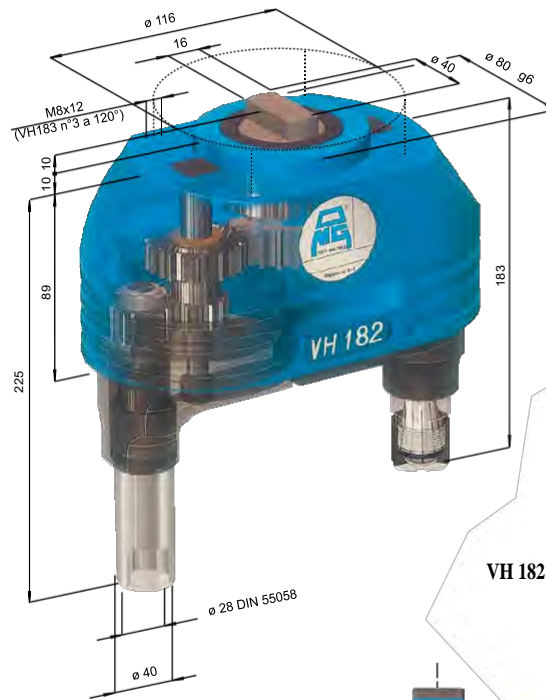
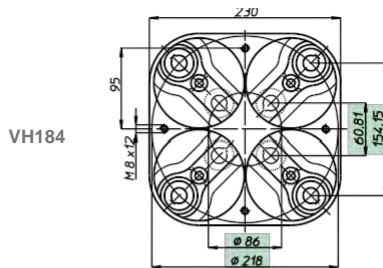
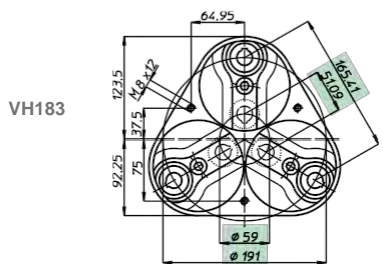
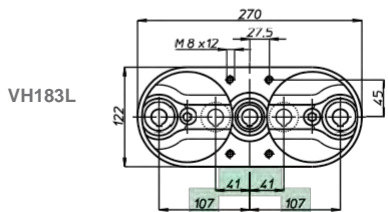
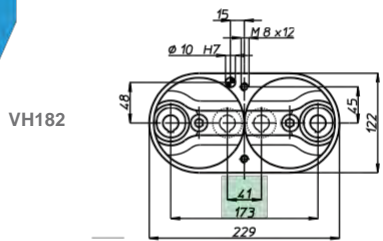

Multispindle headstock model

	VH182	VH183L	VH183	VH184
Article	VH 182 P	VH 183 LP	VH 183 P	VH 184 P
Spindle type	ER25 máx. Ø16			
Article	VH 182 D	VH 183 LD	VH 183 D	VH 184 D
Spindle type	DIN 55058 máx. Ø28			
Spindle number	2	3	3	4
Min. working area	41	41+41	Ø59	Ø89
Max. Distance between centers	173	107+107	Ø191	Ø218
Drilling capacity Steel	Ø18			
Drilling capacity Foundry	Ø20			
Tapping capacity	M14			
Drive relation	1:1			
Allowed maximum revolutions	2.500			
Weight (Kg)	8,3	10,75	12	15,75

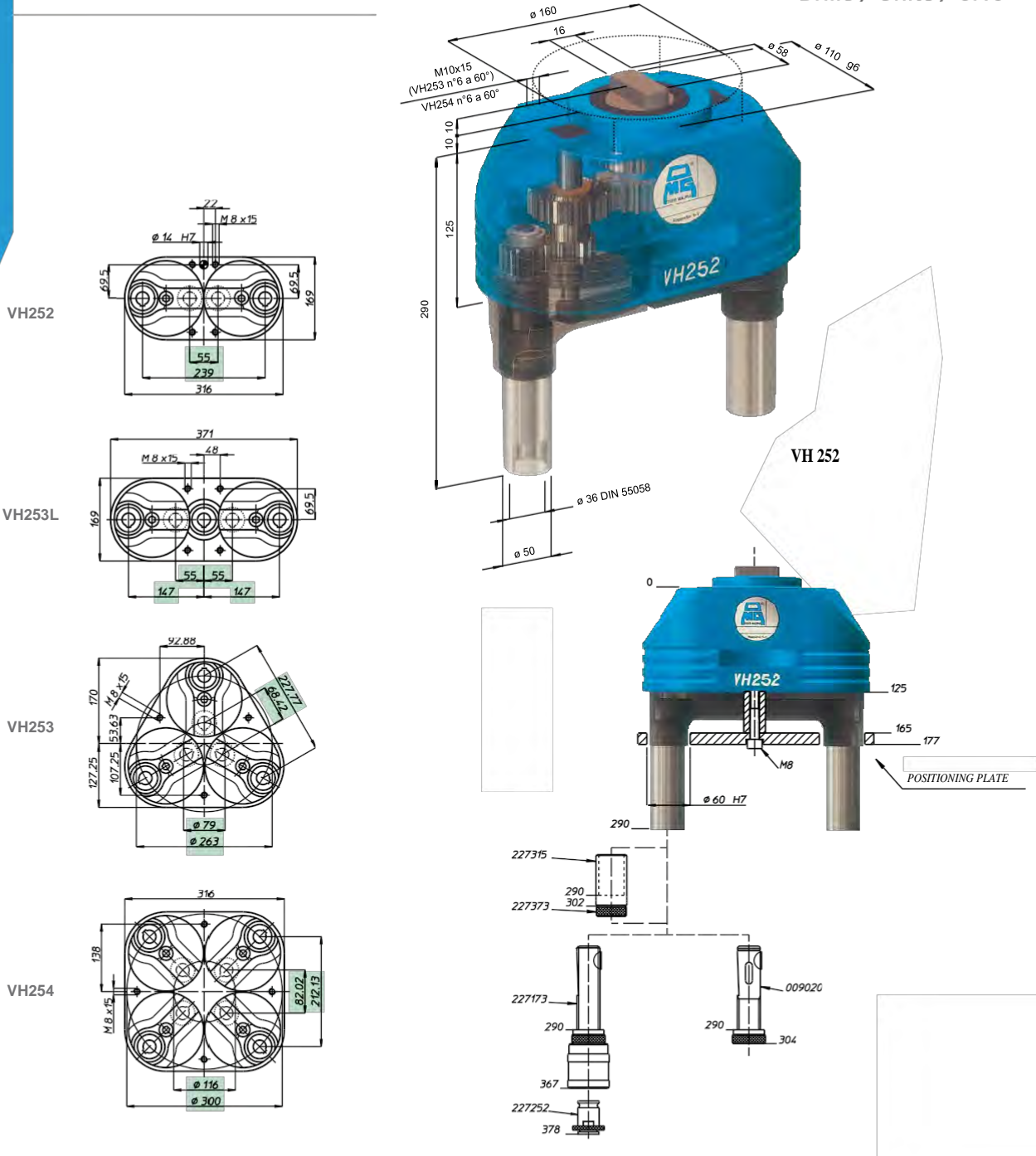

Multispindle headstock model

	VH252	VH253L	VH253	VH254
Article	-	-	-	-
Spindle type				
Article	VH 252 D	VH 253 LD	VH 253 D	VH 254 D
Spindle type		DIN 55058 máx. Ø36		
Spindle number	2	3	3	4
Min. working area	55	55+55	Ø79	Ø116
Max. Distance between centers	239	147+147	Ø263	Ø300
Drilling capacity Steel			Ø25	
Drilling capacity Foundry			Ø28	
Tapping capacity			M20	
Drive relation			1:1	
Allowed maximum revolutions			2.000	
Weight (Kg)	27	32	39,5	52

* Measures can vary without previous notice. Ask for the updated drawing in every case.

TOOL-HOLDERS FOR MACHINING UNITS:

AVAILABLE IN NORMS DIN 2080 / MAS 403 BT / DIN 69871



COMBINED MILL HOLDER:

For shell end mills with driving slot DIN 138

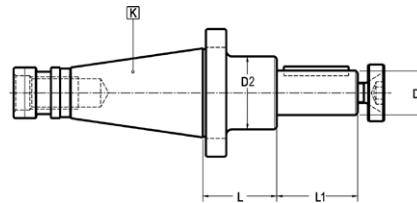

Erlo code	Erlo code	Erlo code	K	D ₁ h6	L	L ₁	L ₂	D ₂
79010-D69871	79010-D2080	79010-M403BT	40	16	request per Norm	17	27	32
79015-D69871		79015-M403BT	40	16	request per Norm	17	27	32
79020-D69871	79020-D2080	79020-M403BT	40	22	request per Norm	19	31	40
79025-D69871		79025-M403BT	40	22	request per Norm	19	31	40
79030-D69871	79030-D2080	79030-M403BT	50	16	request per Norm	17	27	32
79035-D69871		79035-M403BT	50	16	request per Norm	17	27	32
79040-D69871	79040-D2080	79040-M403BT	50	22	request per Norm	19	31	40
79045-D69871		79045-M403BT	50	22	request per Norm	19	31	40
79050-D69871	79050-D2080	79050-M403BT	50	27	request per Norm	21	33	48
79055-D69871		79055-M403BT	50	27	request per Norm	21	33	48



EXTENSIONS AND REDUCING ADAPTERS TO MORSE:

For tangged Morse taper tools DIN-228-B or Morse taper tools with thread DIN-228-A

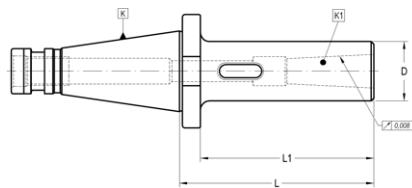

Erlo code	Erlo code	Erlo code	K	K ₁	L	L ₁	D
79100-D69871	79100-D2080	79100-M403BT	30	1	50	request per Norm	25
79105-D69871	79105-D2080	79105-M403BT	30	2	request per Norm	request per Norm	32
79110-D69871	79110-D2080	79110-M403BT	40	3	request per Norm	request per Norm	40
79115-D69871	79115-D2080	79115-M403BT	40	4	request per Norm	request per Norm	48
79120-D69871	79120-D2080	79120-M403BT	50	4	request per Norm	request per Norm	48
79125-D69871	79125-D2080	79125-M403BT	50	5	request per Norm	request per Norm	63

WELDON HOLDERS:

For end mills with shank DIN 1835-B and DIN 6535-HB

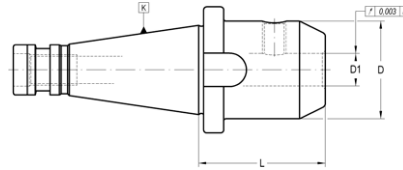

Erlo code	Erlo code	Erlo code	K	D ₁	L	D ₂
79200-D69871	79200-D2080	79200-M403BT	30	6	request per Norm	25
79205-D69871	79205-D2080	79205-M403BT	30	8	request per Norm	28
79210-D69871	79210-D2080	79210-M403BT	30	10	request per Norm	35
79215-D69871	79215-D2080	79215-M403BT	30	12	request per Norm	42
79220-D69871	79220-D2080	79220-M403BT	30	14	request per Norm	44
79225-D69871	79225-D2080	79225-M403BT	40	12	request per Norm	42
79230-D69871	79230-D2080	79230-M403BT	40	14	request per Norm	44
79235-D69871	79235-D2080	79235-M403BT	40	16	request per Norm	48
79240-D69871	79240-D2080	79240-M403BT	40	18	request per Norm	50
79245-D69871	79245-D2080	79245-M403BT	40	20	request per Norm	52
79250-D69871	79250-D2080	79250-M403BT	40	25	request per Norm	65
79255-D69871	79255-D2080	79255-M403BT	40	32	request per Norm	72
79260-D69871	79260-D2080	79260-M403BT	50	25	request per Norm	65
79265-D69871	79265-D2080	79270-M403BT	50	32	request per Norm	72
79270-D69871	79270-D2080	79275-M403BT	50	40	request per Norm	80
79275-D69871	79275-D2080	79280-M403BT	50	50	request per Norm	98

COLLET CHUCKS ER TYPE (DIN 6499):

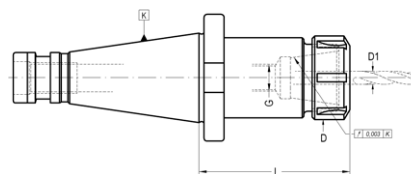

Erlo code	Erlo code	Erlo code	K	Collet size	D ₁ Máx.	L	D	G
79150-D69871	79150-D2080	79150-M403BT	30	ER25	16	request per Norm	42	request per Norm
79155-D69871	79155-D2080	79155-M403BT	40	ER25	16	request per Norm	42	request per Norm
79160-D69871	79160-D2080	79160-M403BT	40	ER32	20	request per Norm	50	request per Norm
79165-D69871	79165-D2080	79165-M403BT	40	ER40	26	request per Norm	63	request per Norm
79170-D69871	79170-D2080	79170-M403BT	50	ER40	26	request per Norm	63	request per Norm
79175-D69871	79175-D2080	79175-M403BT	50	ER50	34	request per Norm	78	request per Norm

QUICK-CHANGE TAPPING CHUCKS:

With self feed and compression system for BILZ system tap adapter

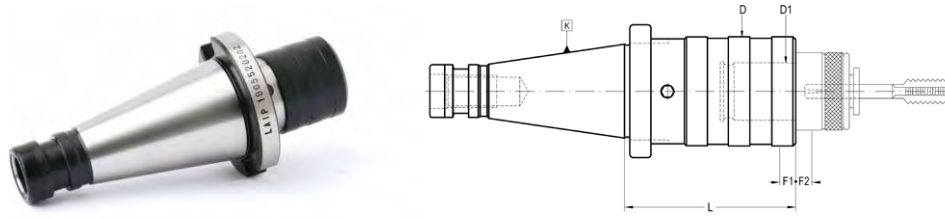

Erlo code	Erlo code	Erlo code	K	CAP.	D ₁	L	D ₂	F ₁	F ₂
79280-D69871	79280-D2080	79280-M403BT	30	M3-M12	19	request per Norm	36	7,5	7,5
79285-D69871	79285-D2080	79285-M403BT	40	M8-M20	31	request per Norm	53	12,5	12,5
79290-D69871	79290-D2080	79290-M403BT	50	M14-M33	48	request per Norm	78	20	20

QUICK-CHANGE DRILL CHUCKS FOR DIN 2080:

Does not require machine stop

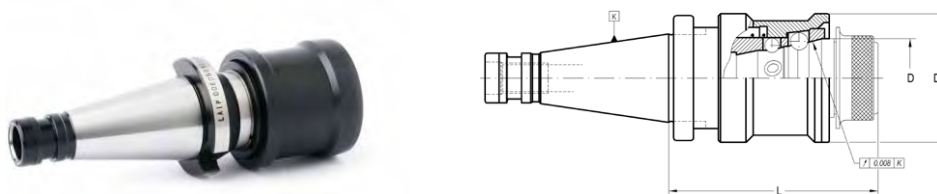

Erlo code	K	D	L	D ₁
79300-D69871	30	40	78	63
79305-D69871	40	51,5	102	83
79310-D69871	50	68,7	133	100

Adapters for all type of tools, such as collet holder ER type, Morse Taper, fitting shank DIN 238, Bilz type tap holders, integral drill chucks, tap holders with double axial compensation, etc.
Please consult.

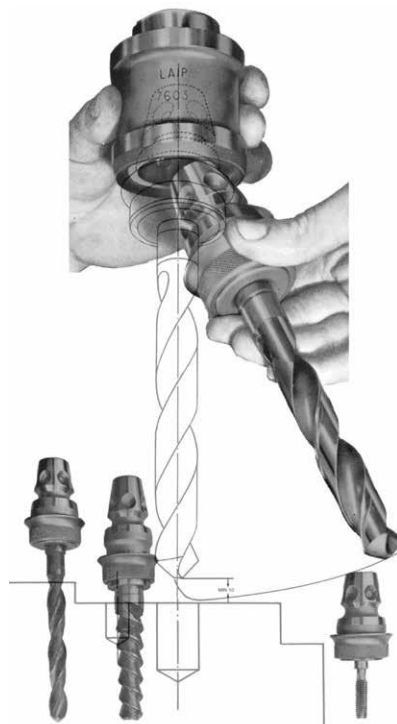

MAHO OTT PULL STUDS:

To adapt MAS 403-BT and DIN 69871 tool-holders to DIN 2080 cone

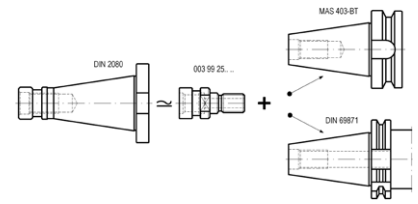
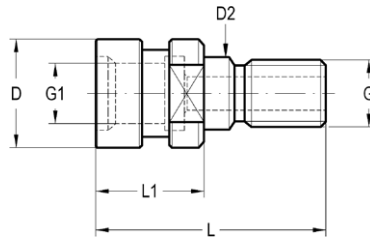

Erlo code	G	G ₁	L	L ₁	D	D ₁
79350-D69871	M16	M16	52	25,15	25	17
79355-D69871	M24	M24	65	25,2	39,3	25

MAS 403 BT PULL STUDS (45°):

With through coolant channel

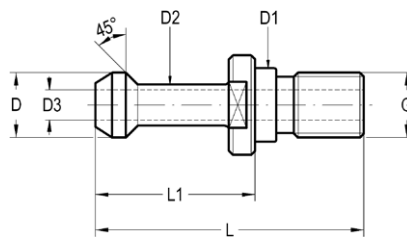

Erlo code	G	G ₁	L	L ₁	D	D ₁
79350-D69871	M16	M16	52	25,15	25	17
79355-D69871	M24	M24	65	25,2	39,3	25

PULL STUDS DIN 69872 (15°):

With through coolant channel

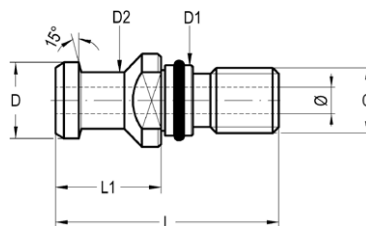

Erlo code	D	G	L	L ₁	D ₁	D ₂
79370-D69871	19	M16	54	26	17	14
79375-D69871	28	M24	74	34	25	21

ERLO
Drills / Units / CNC

ERLO | *Ero
Iberdrill
Ibermach
Ero Service*
Group

www.erlogroup.es

Txerloie auzoa n°3
20720 AZKOITIA
(SPAIN)
T: +34 943 851 858

Email : erlogroup@erlogroup.es